

# \*TB 9-6625-2289-24

DEPARTMENT OF THE ARMY TECHNICAL BULLETIN

## CALIBRATION PROCEDURE FOR ELECTRONIC VOLTMETER AN/URM-145B AND AN/URM-145C (ME-247C/U)

Headquarters, Department of the Army, Washington, DC  
19 February 2009

*Distribution Statement A: Approved for public release; distribution is unlimited.*

### REPORTING OF ERRORS AND RECOMMENDING IMPROVEMENTS

You can improve this manual. If you find any mistakes or if you know of a way to improve these procedures, please let us know. Mail your letter or DA Form 2028 (Recommended Changes to Publications and Blank Forms) directly to: Commander, U.S. Army Aviation and Missile Command, ATTN: AMSAM-MMC-MA-NP, Redstone Arsenal, AL 35898-5000. A reply will be furnished to you. You may also send in your comments electronically to our E-mail address: [2028@redstone.army.mil](mailto:2028@redstone.army.mil) or by fax 256-842-6546/DSN 788-6546. For the World Wide Web use: <https://amcom2028.redstone.army.mil>. Instructions for sending an electronic 2028 can be found at the back of this manual.

SECTION		Paragraph	Page
I.	IDENTIFICATION AND DESCRIPTION		
	Test instrument identification.....	1	2
	Forms, records, and reports.....	2	2
	Calibration description .....	3	2
II.	EQUIPMENT REQUIREMENTS		
	Equipment required .....	4	2
	Accessories required.....	5	3
III.	CALIBRATION PROCESS		
	Preliminary instructions.....	6	3
	Equipment setup .....	7	4
	Accuracy and linearity.....	8	4
	Frequency response.....	9	7
	Power supply.....	10	9
	Final procedure.....	11	9

\*This bulletin supersedes TB 9-6625-2289-35, 16 October 2003, including all changes.

## SECTION I IDENTIFICATION AND DESCRIPTION

**1. Test Instrument Identification.** This bulletin provides instructions for the calibration of Electronic Voltmeter, AN/URM-145B and AN/URM-145C (ME-247C/U). TM-11-6625-524-14-2 was used as the prime data source in compiling these instructions. The equipment being calibrated will be referred to as the TI (test instrument) throughout this bulletin.

**a. Model Variations.** Variations among models are indicated in text.

**b. Time and Technique.** The time required for this calibration is approximately 4 hours, using the dc and low frequency technique.

### 2. Forms, Records, and Reports

**a.** Forms, records, and reports required for calibration personnel at all levels are prescribed by TB 750-25.

**b.** Adjustments to be reported are designated (R) at the end of the sentence in which they appear. When adjustments are in tables, the (R) follows the designated adjustment. Report only those adjustments made and designated with (R).

**3. Calibration Description.** TI parameters and performance specifications which pertain to this calibration are listed in table 1.

Table 1. Calibration Description

Test instrument parameters	Performance specifications <sup>1</sup>		
	Voltage range (V)	Range accuracy (FS)	Frequency response
AN/URM-145C (ME-247C/U)	.003 to 3V	±10%	20 kHz to 100 MHz
		±5%	100 to 400 MHz
	.001	±15%	20 kHz to 100 MHz
		±10%	100 to 400 MHz

<sup>1</sup>Verified to 100 MHz for all systems codes except COO; for COO, verify to 400 MHz.

## SECTION II EQUIPMENT REQUIREMENTS

**4. Equipment Required.** Table 2 identifies the specific equipment to be used in this calibration procedure. This equipment is issued with Secondary Transfer Calibration Standards Set AN/GSM-287 or AN/GSM-705. Alternate items may be used by the calibrating activity. The items selected must be verified to perform satisfactorily prior to use and must bear evidence of current calibration. The equipment must meet or exceed the minimum use specifications listed in table 2. The accuracies listed in table 2 provide a four-to-one ratio between the standard and TI.

**5. Accessories Required.** The accessories required for this calibration are common usage accessories, issued as indicated in paragraph 4 above, and are not listed in this calibration procedure.

Table 2. Minimum Specifications of Equipment Required

Common name	Minimum use specifications	Manufacturer and model (part number)
CALIBRATOR	Frequency range: 20 kHz to 1 MHz Voltage range: 0.15 mV to 3.3 V ac Accuracy: ±2.5	Fluke, Model 5720A (5700A/EP) (p/o MIS-35947); w/ amplifier, Fluke 5725A/AR (5725A/AR)
FREQUENCY COUNTER	Range: 94.00 Hz Accuracy: ±0.52%	Fluke, Model PM6681/656 (PM6681/656)
MEASURING RECEIVER	Frequency range: 10 to 400 MHz Range: 0 to 110 mV rms Accuracy: ±1.25	Measuring receiver system N5530S consisting of: Spectrum Analyzer, Agilent Model E4440A (E4440A), Power meter, Agilent Model E4419B (E4419B), and Sensor module, Agilent Model 504 (504)
MULTIMETER	Range: -15.01 mV to +15.01 V dc Accuracy: ±0.0167%	Fluke, Model 8840A/AF05 (AN/GSM-64D)
POWER SPLITTER	Frequency range: 10 to 400 MHz Port-to-port tracking accuracy: ±0.15 dB	Weinschel, Model 1870A (7916839)
SIGNAL GENERATOR	Range: 3 to 400 MHz Output amplitude variable from 90 to 110 mV	Aeroflex, Model 2023B (2023B) or (SG-1207/U)

### SECTION III CALIBRATION PROCESS

**6. Preliminary Instructions**

a. The instructions outlined in paragraphs 6 and 7 are preparatory to the calibration process. Personnel should become familiar with the entire bulletin before beginning the calibration.

b. Items of equipment used in this procedure are referenced within the text by common name as listed in table 2.

c. Unless otherwise specified, verify the result of each test and, whenever the test requirement is not met, take corrective action before continuing with the calibration. Adjustments required to calibrate the TI are included in this procedure. Additional maintenance information is contained in the manufacturer's manual and TM 11-6625-524-14-2 for this TI.

d. Unless otherwise specified all controls and control settings refer to the TI.

## 7. Equipment Setup

### WARNING

HIGH VOLTAGE is used or exposed during the performance of this calibration. DEATH ON CONTACT may result if personnel fail to observe safety precautions. REDUCE OUTPUT(S) to minimum after each step within the performance check where applicable.

- a. Mechanically zero TI meter.
- b. Connect RF probe to **PROBE** jack.

### NOTE

The RF probe authorized for use with TI must have serial numbers matching the TI serial numbers. If a new RF probe is calibrated with TI, annotate new RF probe with TI serial number. Do not use any RF probe not calibrated with TI.

- c. Connect TI to a 115 V ac source.
- d. Set **OFF-ON** switch to **ON**.
- e. Set **RANGE** switch to **.001 VOLTS**.
- f. Replace TI RF probe tip with test adapter (50  $\Omega$  feedthrough termination).
- g. Adjust **ZERO** control for TI indication of **0**.

### NOTE

If noise is present, adjust **ZERO** control for an average TI indication of **0**.

- h. Replace test adapter (50  $\Omega$  feedthrough termination) with TI RF probe tip.
- i. Allow TI to warm-up for 5 minutes.
- j. Allow measuring receiver to warm-up for 30 minutes.

### NOTE

Ensure proper calibration factors are used for measuring receiver sensor module selected.

## 8. Accuracy and Linearity

### a. Performance Check

- (1) Set calibrator for wideband operation.
- (2) Connect calibrator **WIDEBAND OUTPUT** (without 50 ohm pad) to TI RF probe using 50 ohm feedthrough termination supplied with TI.
- (3) Adjust calibrator frequency controls for 50 kHz output.

- (4) Adjust calibrator voltage output controls for a TI meter indication specified in table 3. If calibrator does not indicate within the limits specified in table 3, perform **b** below.
- (5) Repeat technique of (4) above for remaining **RANGE** settings listed in table 3.

Table 3. Range Accuracy and Linearity

RANGE settings	Test instrument meter indications (V)	Calibrator indications	
		Min	Max
.001	.001	.85 mV	1.15 mV
.003	.003	2.7 mV	3.3 mV
.01	.01	9.0 mV	11.0 mV
.03	.03	27.0 mV	33.0 mV
.1	.1	90.0 mV	110.0 mV
.3	.3	.270 V	.330 V
1	1	.9 V	1.1 V
3	3	2.7 V	3.3 V

- (6) Set calibrator to standby.
- (7) Disconnect TI RF probe from calibrator output.

**b. Adjustments**

**NOTE**

Ensure calibrator frequency controls are set for 50 kHz output.

- (1) Connect TI RF probe to calibrator **WIDEBAND OUTPUT**.
- (2) Set **RANGE** switch to **1.0**.
- (3) Adjust calibrator voltage output controls for a TI meter indication of 1.0 V ac.
- (4) Connect frequency counter low lead to TI chassis.
- (5) Connect frequency counter high lead to TI A5E1.
- (6) Adjust R2 (fig. 1) for a frequency counter indication between 92 and 96 Hz (R).
- (7) Disconnect TI from frequency counter and calibrator.
- (8) Set TI **RANGE** switch to **.001 VOLTS**.
- (9) Disconnect TI RF probe from calibrator.
- (10) Zero TI meter with **ZERO** control.

**NOTE**

If necessary, repeat **7 g** through **i** above.

- (11) Set TI **RANGE** switch to **.3 VOLTS** and adjust R34 **ZERO** (fig. 1) for TI meter indication of 0.
- (12) Set **RANGE** switch to **3.0 VOLTS**.

**NOTE**

Operate calibrator in wideband operation.

- (13) Connect TI probe to calibrator **WIDEBAND OUTPUT**.
- (14) Adjust calibrator voltage controls for 3.0 V ac output at 50 kHz.
- (15) Adjust **METER CAL R49** (fig. 1) for a TI indication between 2.7 and 3.3 V ac (ideal 3.0 V ac) (R).
- (16) Set **RANGE** switch to **.001 VOLTS**.
- (17) Disconnect RF probe from calibrator.
- (18) Zero TI meter with **ZERO** control.

**NOTE**

If necessary, repeat 7 g through i above.

- (19) Connect probe to calibrator **WIDEBAND OUTPUT**.
- (20) Adjust calibrator for 1 mV ac output and then adjust **R3** (fig. 1) for a TI indication between .00085 and .001 15 V ac (ideal .001 V ac) (R).
- (21) Set **RANGE** switch to **.003 VOLTS**.
- (22) Disconnect RF probe from calibrator.
- (23) Zero TI meter with **ZERO** control.

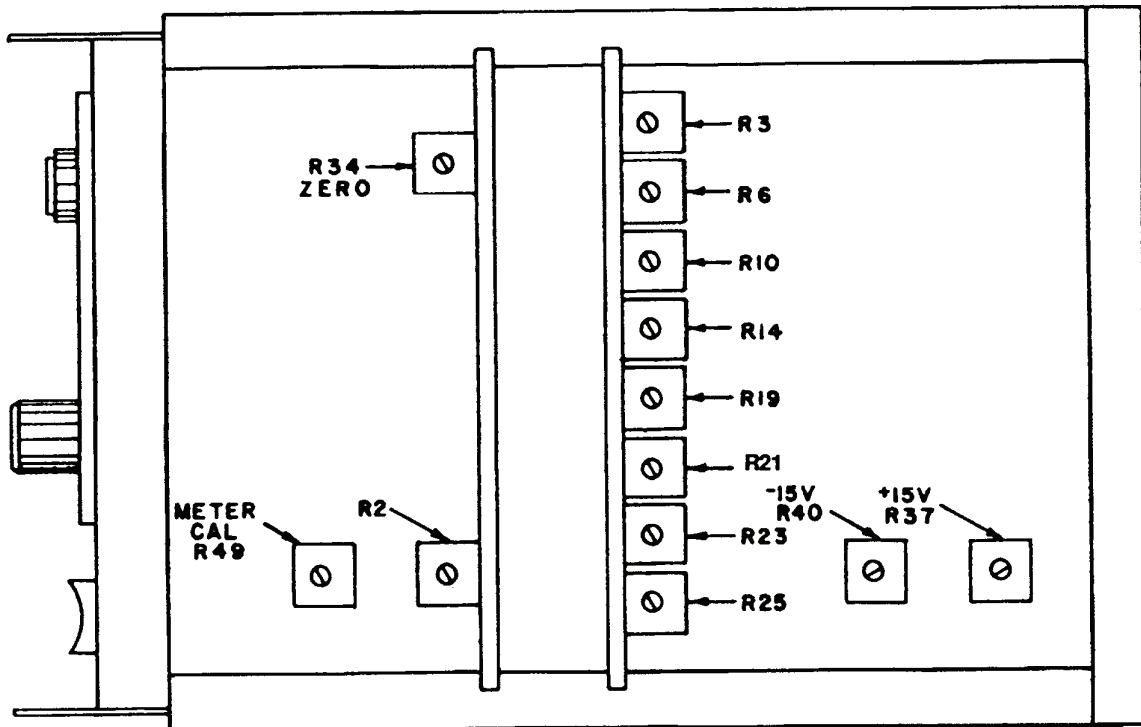

Figure 1. AN/URM-145C.

**NOTE**

If necessary, repeat **7 g** through **i** above.

- (24) Connect RF probe to calibrator **WIDEBAND OUTPUT**.
- (25) Adjust calibrator for 3 mV ac output and then adjust R6 (fig. 1) for a TI indication between .0027 and .0033 V ac (ideal .003 V ac) (R).
- (26) Set **RANGE** switch to **.1-VOLTS**. Adjust calibrator for .10 V ac output and then adjust R19 (fig. 1) for a TI indication between .09 and 0.11 V ac (ideal .1 V ac) (R).
- (27) Set **RANGE** switch to **.3 VOLTS**. Adjust calibrator for .3 V ac output and then adjust R21 (fig. 1) for a TI indication between .27 and .33 V ac (ideal .3 V ac) (R).
- (28) Set **RANGE** switch to **.01 VOLTS**. Adjust calibrator for .01 V ac output and then adjust R10 (fig. 1) for a TI indication between .009 and .011 V ac (ideal .01 V ac) (R).
- (29) Set **RANGE** switch to **.03 VOLTS**. Adjust calibrator for .03 V ac output and then adjust R14 (fig. 1) for a TI indication between .027 and .033 V ac (ideal .030 V ac) (R).
- (30) Set **RANGE** switch to **1 VOLTS**. Adjust calibrator for 1 V ac output and then adjust R23 (fig. 1) for a TI indication between .9 and 1.1 V ac (ideal 1.0 V ac) (R).
- (31) Set **RANGE** switch to **3 VOLTS**. Adjust calibrator for 3.0 V ac output and then adjust R25 (fig. 1) for a TI indication between 2.7 and 3.3 V ac (ideal 3.00 V ac) (R).

**9. Frequency Response**

**a. Performance Test**

- (1) Connect calibrator **WIDEBAND OUTPUT** (without 50 ohm pad) to TI RF probe using 50 Ω feed through termination supplied with TI.
- (2) Set **RANGE-FULL SCALE SWITCH** to **.1 VOLTS**.
- (3) Adjust calibrator frequency controls to values listed in table 4.
- (4) Adjust calibrator output voltage controls for .1 V indication on TI meter. Calibrator voltage output will be within the limits specified in table 4.
- (5) Repeat (3) and (4) above for remaining calibrator frequency settings listed in table 4.

Table 4. Frequency Response

Calibrator frequency settings (kHz)	Calibrator output voltage indications (mV)	
	Min	Max
20	90	110
50	90	110
100	90	110
500	90	110
1000	90	110

- (6) Connect equipment as shown in figure 2.

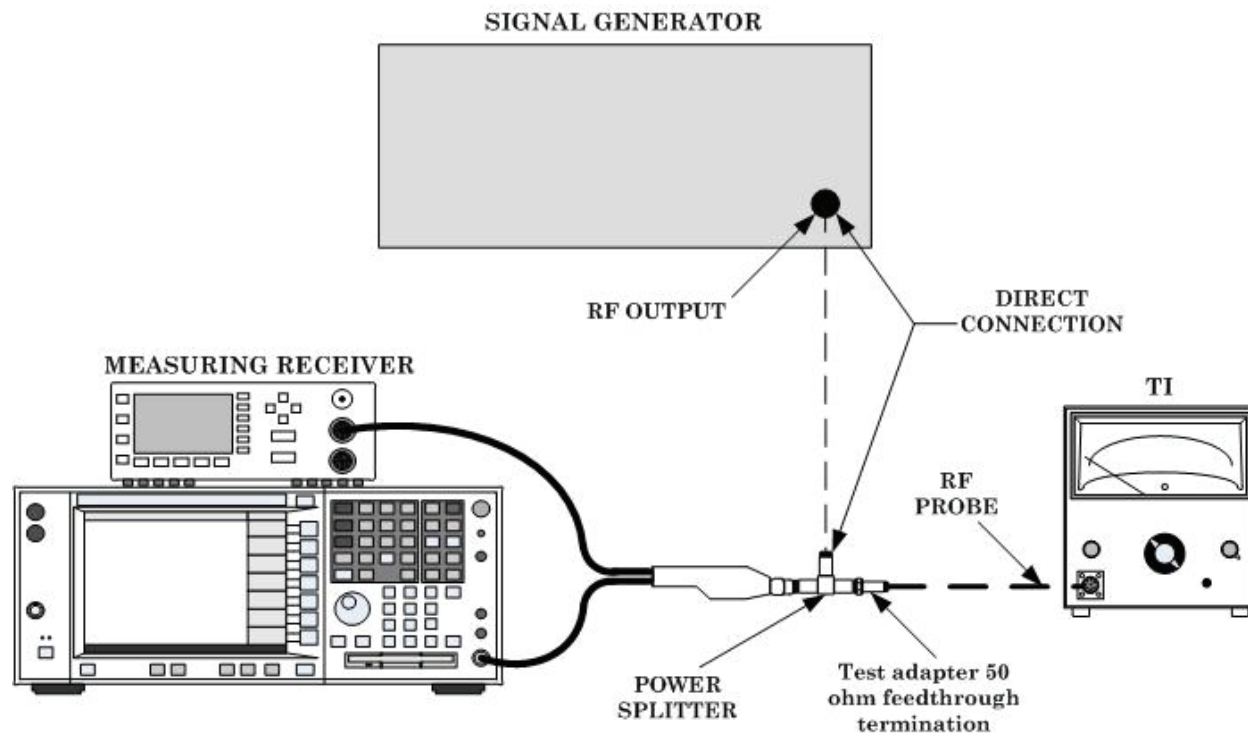

Figure 2. Frequency response - equipment setup.

- (7) Adjust signal generator frequency controls to value listed in signal generator frequency settings listed in table 5.
- (8) Configure measuring receiver to measure RF power in mV.
- (9) Measuring receiver indications will be within the limits listed in table 5.
- (10) Adjust signal generator for remaining frequency settings listed in table 5. Measuring receiver indication for remaining frequency settings will be within limits specified in table 5.

Table 5. Frequency Response

Signal generator frequency settings (MHz)	Measuring receiver voltage indications (mV)	
	Min	Max
3	90	110
5	90	110
7	90	110
10	90	110
20	90	110
50	90	110
90	90	110
120	95	105
200	95	105
300	95	105
400	95	105



**b. Adjustments.** No adjustments can be made.

## 10. Power Supply

### NOTE

Do not perform power supply check if all other parameters are within tolerance.

**a. Performance Check.** Connect digital multimeter positive lead to 3A1TP1 (fig. 3) and connect negative lead to 3A1TP2 (fig. 3). If digital multimeter does not indicate between +14.49 and +14.51 V dc, perform **b** (1) below.

**b. Adjustments.** Adjust 3A1R13 (fig. 3) for a digital multimeter indication between +14.49 and +14.51 V dc (ideal 14.50 V dc) (R).

## 11. Final Procedure

**a.** Deenergize and disconnect all equipment.

**b.** Annotate and affix DA label/form in accordance with TB 750-25.

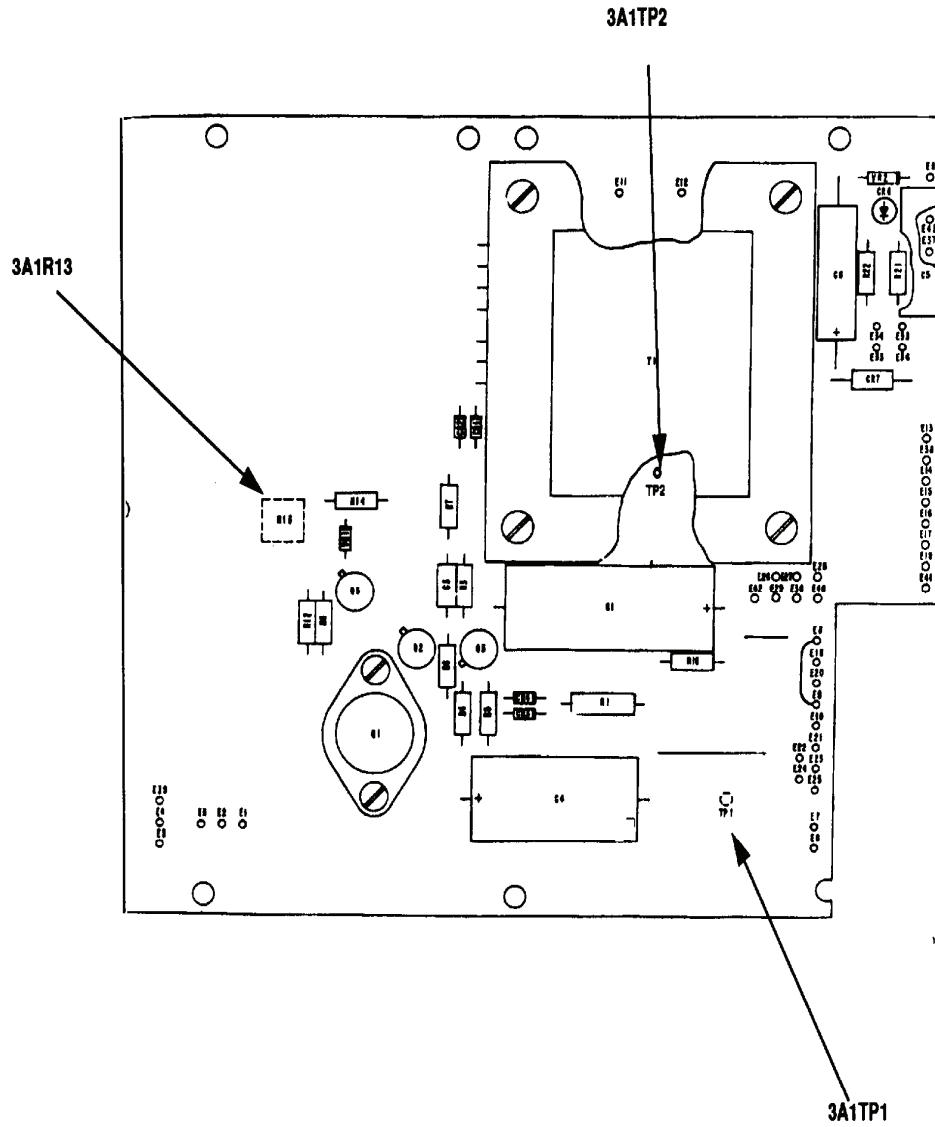



Figure 3. Regulated power supply 3A1 - location of parts.

By Order of the Secretary of the Army:

Official:

  
JOYCE E. MORROW  
*Administrative Assistant to the  
Secretary of the Army*

0719029

GEORGE W. CASEY, JR.  
*General, United States Army  
Chief of Staff*

Distribution:

To be distributed in accordance with the initial distribution number (IDN) 344469 requirements for calibration procedure TB 9-6625-2289-24.



### Instructions for Submitting an Electronic 2028

The following format must be used if submitting an electronic 2028. The subject line must be exactly the same and all fields must be included; however, only the following fields are mandatory: 1, 3, 4, 5, 6, 7, 8, 9, 10, 13, 15, 16, 17, and 27.

From: "Whomever" [whomever@redstone.army.mil](mailto:whomever@redstone.army.mil)  
To: <2028@redstone.army.mil

Subject: DA Form 2028

1. **From:** Joe Smith
2. **Unit:** home
3. **Address:** 4300 Park
4. **City:** Hometown
5. **St:** MO
6. **Zip:** 77777
7. **Date Sent:** 19-OCT -93
8. **Pub no:** 55-2840-229-23
9. **Pub Title:** TM
10. **Publication Date:** 04-JUL-85
11. **Change Number:** 7
12. **Submitter Rank:** MSG
13. **Submitter FName:** Joe
14. **Submitter MName:** T
15. **Submitter LName:** Smith
16. **Submitter Phone:** 123-123-1234
17. **Problem:** 1
18. **Page:** 2
19. **Paragraph:** 3
20. **Line:** 4
21. **NSN:** 5
22. **Reference:** 6
23. **Figure:** 7
24. **Table:** 8
25. **Item:** 9
26. **Total:** 123
27. **Text**

This is the text for the problem below line 27.





